

# Installation Instructions for EMPI Rear Disc Brake Kit

## Step 1

- Check that you have received all the components on the parts list.
- Read the installation instructions carefully before starting installation.
- If you have any doubts about your ability to correctly install the Disc Brake Conversion kit, please contact a qualified repair shop.
- We suggest that you have a Bentley or Haynes Service manual handy for some procedures and specifications.

## Step 2

- Remove the rear axle nut and brake drum.
- Remove existing brake shoe components.
- Disconnect steel brake line and brake hose from wheel cylinder.
- Remove wheel cylinder and backing plate.
- Remove the bearing seal cap.

**Note:** On swing axle cars, the original brake lines can be re-used. On I.R.S. and long swing axle cars longer brake lines (approx. 30") must be used (Not Supplied). **DO NOT DISCARD ANY PARTS** until the installation is complete as the axle nuts, bearing caps etc. must be re-used.

## Step 3 (See parts break down illustration)

- Install the bearing thrust washer, small o-ring, and original spacer on axle (Small o-ring not required on I.R.S.).
- Install the caliper bracket and large o-ring on the bearing flange.
- Install the bearing seal cap with new seal and oil deflector. Using only 1 gasket between bearing cap and caliper bracket. Torque the bearing seal cap bolts to **25 ft. lbs.**

**Note:** If car is equipped with early (pre 1960) bearing seal cap the brake rotor will not seat properly. The later version bearing seal cap must be used.

## Step 4

- Install the disc brake rotor and tighten the axle nut.

**Note:** Axle nuts must be re-tightened and torque to at least 250 ft. lbs. after installation is complete and car is on the ground.

## Step 5

- Remove the plastic brake pad spreaders from the caliper and install the caliper, (make sure the bleeder screw is on the top, as there is a left, and right side) with the 10mm bolts and washer supplied in kit, and torque to **25 ft. lbs.**
- Re-attach the brake line. On swing axle cars the original brake lines can be used, but must be re-shaped. Use a hand held bending tool to avoid crimping the line. Install the adapter furnished in the kit to adapt the caliper to your existing line. On I.R.S. cars, new 30 inch brake Lines must be used (Not supplied).
- When installing this kit, it is recommended that a thread-locker be applied to caliper hardware.

Repeat installation procedure on the other side of car.

## Step 6

- Bleed the brake system of air. Check that there are no brake fluid leaks and top off fluid reservoir.

## Step 7

- For kits with parking brakes. Install hose adapters with washer onto calipers. Remove existing parking brake cables and install new cables. Secure at caliper with "C" clips. (Refer to a workshop manual for adjustment).
- The ball on the cable goes into the arm with the spring and washer secured underneath.

Lower car to ground and torque axle nuts to at least 250 ft. lbs.

Test drive car to insure that brakes operate correctly.

## Swing Axle Applications:

Qty.	Description
2	Rear Axle Seal Kit
2	Brake Disc
2	Caliper Bracket
1	Left Caliper
1	Right Caliper
4	10mm x 25mm Hex Bolt with Washer
2	*C-Clip for Parking Brake Cables
2	*Caliper/Brake Line Adapters w/ Washers
2	*Parking Brake Cable

\*Specified Kits

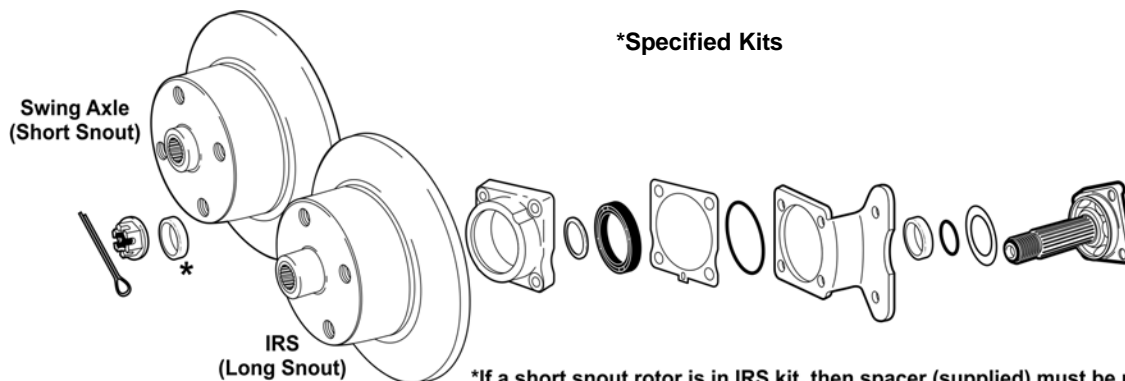

## I.R.S. Applications:

Qty.	Description
2	Rear Axle Seal Kit
2	Brake Disc
2	Caliper Bracket
1	Left Caliper
1	Right Caliper
4	10mm x 25mm Hex Bolt with Washer
2	*C-Clip for Parking Brake Cables
2	*Caliper/Brake Line Adapters w/ Washers
2	*Parking Brake Cable

\*Specified Kits



# BRAKE PAD INSTALLATION INSTRUCTIONS FOR EMPI BRAKE CALIPERS UTILIZING AN EMERGENCY BRAKE.

22-6123-B / 22-6124-B

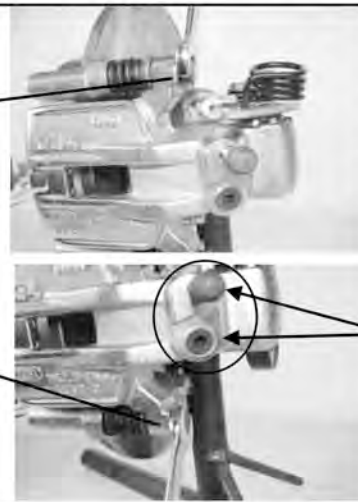
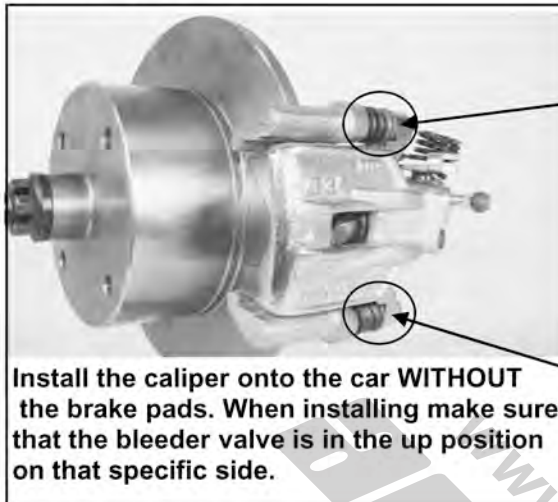

Loosen both the top and bottom bolts that hold the caliper to the guide pins that are covered by the rubber boot. Do not remove the bottom bolt. This bolt only needs to be loosened 1 or 2 turns.

This is the Left side caliper with the Bleeder valve above the line inlet

Install the caliper onto the car WITHOUT the brake pads. When installing make sure that the bleeder valve is in the up position on that specific side.

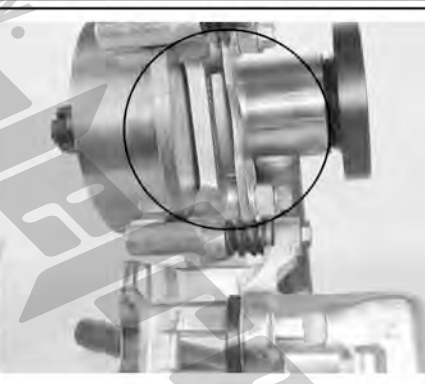

Remove the top bolt completely and rotate the caliper open, this will gain you access to the rotor and bracket and allow you to install the brake pads.

install the brake pads into caliper bracket against the rotor.

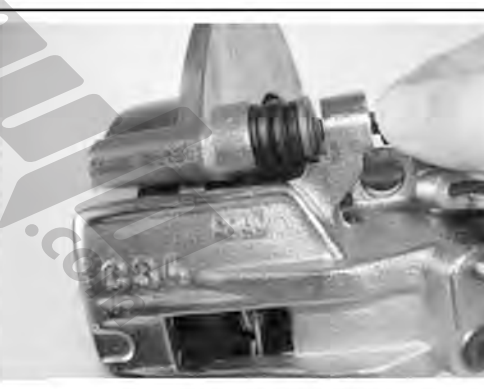
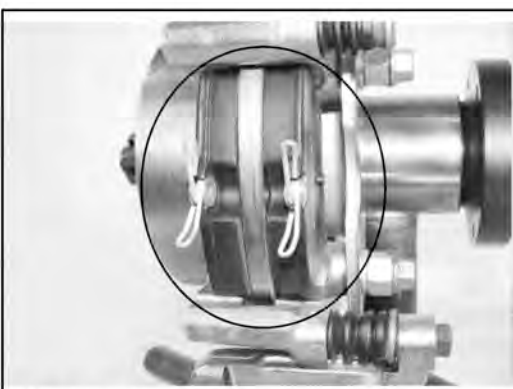

With the brake pads in place, you can close the caliper, the tension springs on the pads will push against the inside of the top of the caliper and provide some resistance. This is normal. The tension springs hold the pads in place. Re install the top bolt (see detail below) and tighten both the top and bottom bolts completely.

When reinstalling and tightening the top bolt, be sure that the flat portion of the nut for the pin with the boot on it is aligned with the flat recess on the caliper.



Your pads are now installed and you are ready to finish your installation.



**Instructions for Brake Kits: 22-2865, 22-2870, 22-2871, 22-2905,  
22-2906, 22-2907, 22-2912, 22-2913, 22-2914**

Install the male end of this intermediate brake hose directly into the adapter. Your existing metal brake line installs into the female end.

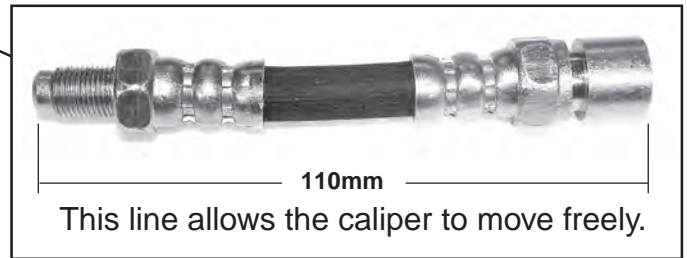
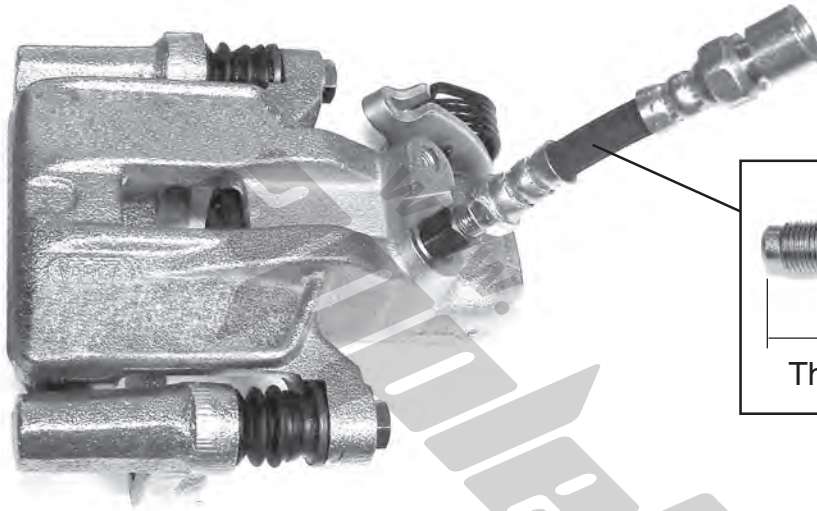

99-4090/1006



**Instructions for Brake Kits: 22-2865, 22-2870, 22-2871, 22-2905,  
22-2906, 22-2907, 22-2912, 22-2913, 22-2914**

Install the male end of this intermediate brake hose directly into the adapter. Your existing metal brake line installs into the female end.

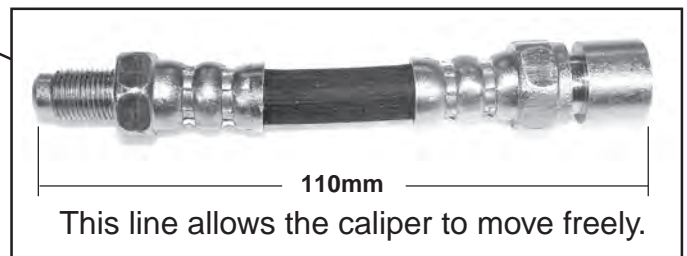
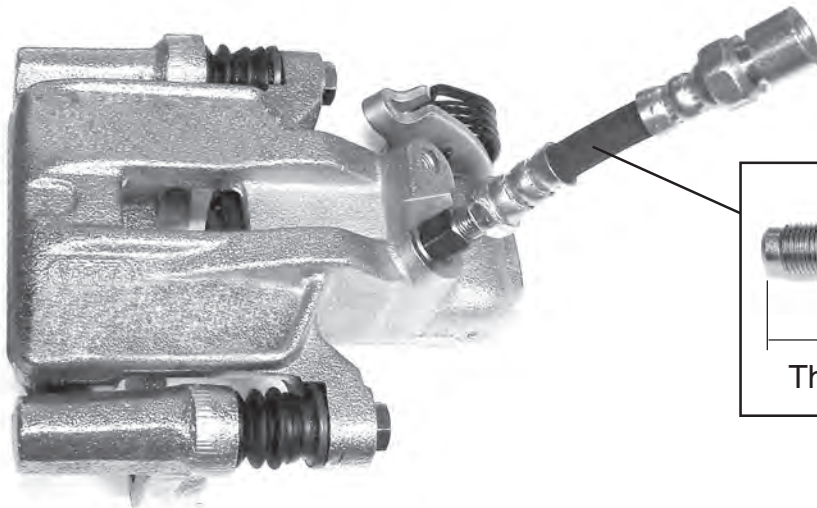

99-4090/1006