

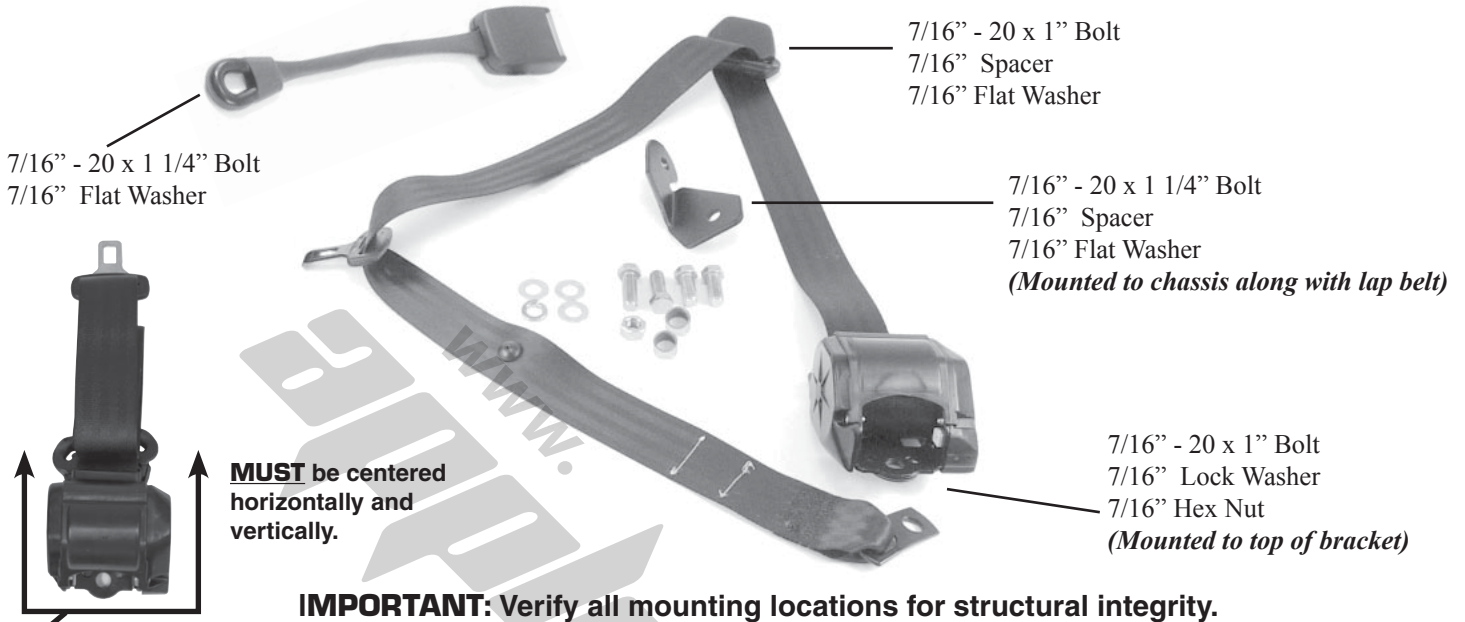

# Instructions for 3851

For use in 1968 & newer Type 1 Sedans, utilizing O.E. mounting locations



**Note:** Due to the design nature of the winder/locking mechanism, this unit will not dispense or retract the belt unless it is centered both horizontally and vertically. If the reel has retracted too much belt onto it, it may require some hand feeding to get the mechanism back into it's working range.

99-4091-0



# Instructions for 3851

For use in 1968 & newer Type 1 Sedans, utilizing O.E. mounting locations

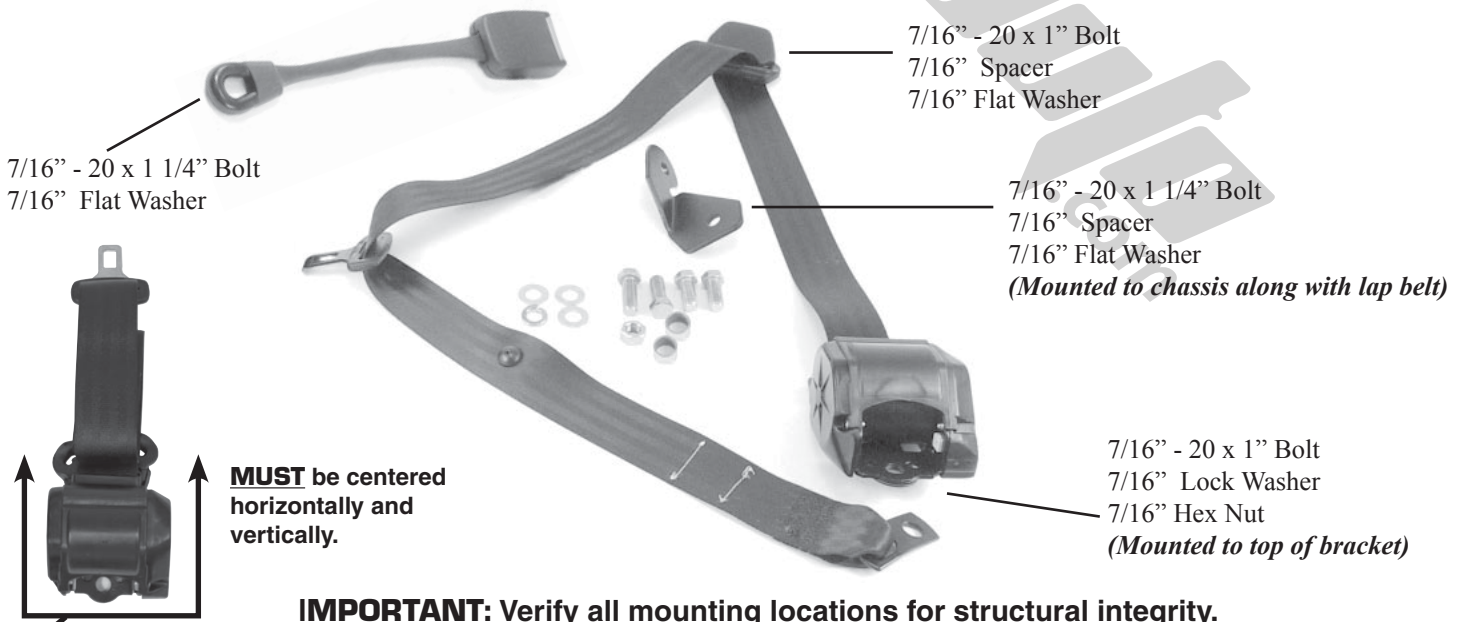

**Note:** Due to the design nature of the winder/locking mechanism, this unit will not dispense or retract the belt unless it is centered both horizontally and vertically. If the reel has retracted too much belt onto it, it may require some hand feeding to get the mechanism back into it's working range.

99-4091-0