



INSTALLATION INSTRUCTIONS FOR TYPE 1 SINGLE EMPI HPMX & IDF KITS



READ THOROUGHLY ALL STEPS OF THESE INSTRUCTIONS BEFORE BEGINNING THIS INSTALLATION.

TOOLS AND EQUIPMENT NEEDED:

Combination, box or open end wrenches (metric + U.S.)
 Socket set metric
 Screwdriver (Regular and Phillips)
 Pliers 3/8" Drive Ratchet
 Gasket Scraper 3/8" Drive Swivel
 Rags 3/8" Drive Extension (10-12")
 Cleaning Solvent 3/8" open-end Wrench
 Knife Allen Wrenches
 Gasket Sealer Wire Cutters

PARTS SUPPLIED WITH INSTALLATION KIT:

1 - Hardware Kit
 1 - Intake Manifold
 1 - Carburetor
 1 - Air Filter Assembly
 1 - Fuel Line

Your EMPI carburetor(s) come equipped with the Main, Air, and Idle jets most often used in the kit's particular application. Although it is a bolt-on kit, with the necessary hardware, gaskets and linkage to install the carburetor(s) onto the desired motor - The carburetor(s) are jetted not engine size specific. Multiple engine displacements, compression, camshafts, ignition, cylinder heads, and many other items such as operating elevation, will affect the overall requirements of the air/fuel ratio and may require additional jetting and tuning. A wide variety of jets and components are available at your EMPI dealer.

1. Mount manifold to engine case utilizing existing case stud if long enough. If stud is not long enough, remove stud and secure manifold with M8 X 55 bolt and M8 washer supplied. Mount end casting to heads and manifold. (Manifold tubes can be shortened if necessary).
2. Install M8 X 40 studs on manifold and mount carburetor to manifold using supplied gaskets.
3. Mount new flat carburetor arm on carb throttle shaft as shown in **Figure 2** (Approx. the 5 o'clock position). **DO NOT OVER TIGHTEN THROTTLE SHAFT NUTS, 4-5FT/LBS MAXIMUM.** Slide shaft with carb arm through outside ear on manifold. Before sliding shaft through second ear, slide collar with set screw onto shaft. Slide the shaft the rest of the way through the second mount ear. Position lock collar next to left side edge of **FIRST** ear (This will keep linkage from "walking"), loosely tighten. Slide bent throttle cable arm onto shaft with short ear facing to the right, loosely tighten (**See Figure 3**).
4. Mount swivel joint to 1/4-28 stud, then thread 1/4-28 jam nut onto stud. Add other swivel joint to stud. Only one lock nut is necessary to maintain the set length. Attach one swivel end to carb arm on carburetor and the other one to the arm with shaft. The arm with shaft (on manifold) should be pointing at approx. 7 o'clock. Attach throttle cable to throttle arm with barrel nut supplied. Check and adjust all linkage for full travel. **NOTE: WHEN SETTING THE CABLE ADJUSTMENT AT THROTTLE ARM, BE SURE TO SET AT "FULL THROTTLE POSITION". THIS MEANS THE ACCELERATOR PEDAL SHOULD BE AT "FULL STOP" AND THEN CABLE IS SET AT CARBURETOR "FULL THROTTLE STOP". THIS WILL KEEP YOU FROM OVER-EXTENDING YOUR CARBURETOR LINKAGE AND THROTTLE SHAFTS.** Tighten all set screws and nuts.
5. Refer to tuning/adjustment sheet (Included) for any necessary carburetor fine tuning.
6. Install air cleaner assembly.

Figure 1

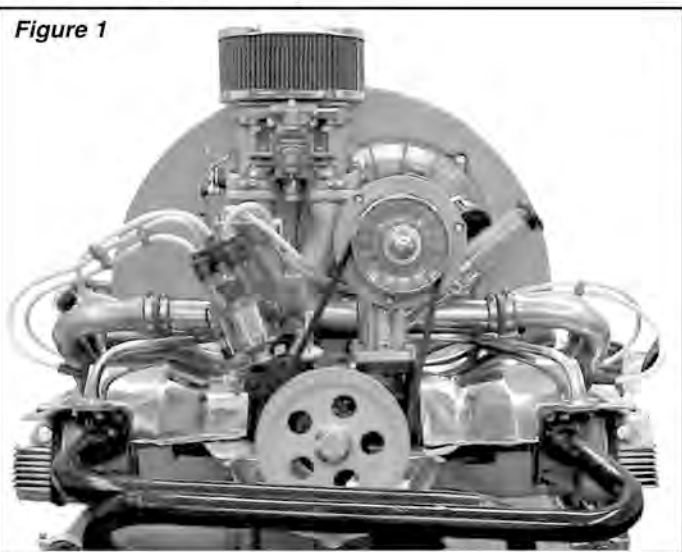

Figure 2



Figure 3





40/44 EMPI HPMX Carburetors

Basic Lean Best Idle Adjustments

Please note: The adjustments listed on this page are approximate lean best idle starting points. EMPI USA is not responsible for tuner error.

1. Air Bleed screws are to air be lightly seated, Close the air bleed screws clockwise until lightly seated. Tighten the lock nut when bleed screws are closed.
2. Mixture Screws are adjusted from the closed position, turn clockwise until lightly seated, Counter clockwise out 1 ½ turns for adjustment.
3. Idle Speed Screws are adjusted from the first point of contact with the linkage arm. Adjust the Idle speed screw clockwise ½ turn after first contact with the linkage arm.

Adjustment for the accelerator pump rod needs to be 7mm from the end of the rod to the top of the nylock nut. These adjustments have varied on each carburetor. This is critical!

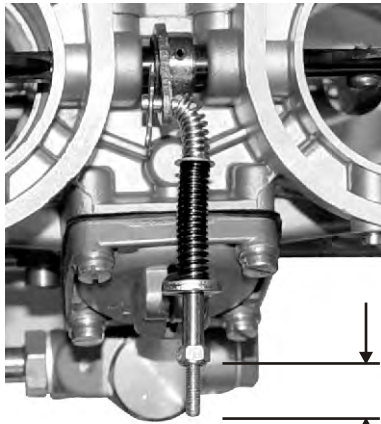

7mm

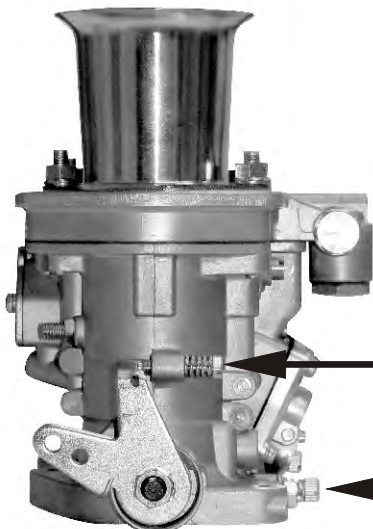
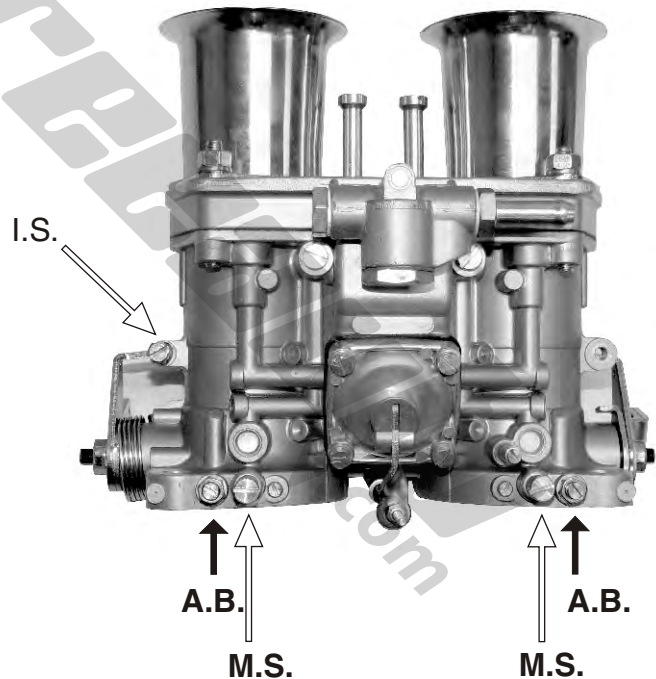

Idle Speed Screw

Turn clockwise ½ turn from first contact with the linkage arm

Mixture Screws

Lightly seat (close) mixture screws clockwise, Then Turn counter clockwise out 1 ½ turns each for setting.