



# INSTALLATION INSTRUCTIONS

## Installation Instructions MSD Billet VW Distributor PN 8485

**Important:** Read these Instructions before attempting the installation.

### Contents

Timing Functions  
Choosing an Advance Curve  
Setting or Locking Out the Centrifugal Advance  
Installing the Distributor  
Wiring the Distributor

### Parts Included In This Kit

1 Billet Distributor  
2 #10 Disc Washers  
3 Advance Stops  
1 Retaining Nut  
7 Shims  
1 Clamp Stud  
4 Advance Springs  
1 Hold Down Bracket  
2 O-Rings

## TIMING FUNCTIONS

Before continuing with the installation, here are a few definitions you should be aware of:

**Initial Timing:** This is the base timing of the engine before centrifugal advance begins.

**Centrifugal Advance:** The centrifugal advance mechanism is made up of weights, springs, advance cam, and an advance stop bushing. The amount and rate of advance that your distributor is capable of is determined by the centrifugal timing. If you ever wish to lock out the centrifugal advance, refer to the centrifugal advance section.

**Total Timing:** This is the total of the initial timing plus the centrifugal advance added together. Example:  $10^{\circ}$  Initial +  $25^{\circ}$  centrifugal =  $35^{\circ}$  Total Timing.

## CHOOSING AN ADVANCE CURVE

The function of the advance curve is to match the ignition timing to the burning rate of the fuel and speed (rpm) of the engine. Any factor that changes the burning rate of the fuel or the engine speed can cause a need for an ignition timing change. Figure 1 shows some of the factors that will affect engine timing.

FACTOR	Advance Timing For	Retard Timing For
Cylinder Pressure	Low	High
RPM	High	Low
Vacuum	High	Low
Energy of Ignition	Low	High
Fuel Octane	High	Low
Mixture (Air/Fuel)	Rich	Lean
Temperature	Cool	Hot
Combustion Chamber Shape	Open	Compact
Spark Plug Location	Offset	Center
Combustion Turbulence	Low	High
Load	Light	Heavy

**Figure 1 Ignition Timing Factors.**

As you can see from the chart, most factors will change throughout the range of the engine operation. The timing mechanism of the distributor must make timing changes based on these factors.

**Example:** An engine has 11.5:1 compression, a high energy ignition and turns 5,500 rpm. With the specifications given, you will have to retard the timing for the high compression, low rpm and high energy ignition. By comparing the engine's specifications against the chart, a usable timing guideline can be found. Engines with a combination of items from both columns will require a timing that is set in the mid range.

Obviously a full technical explanation of correct ignition timing would be very complicated. The best way to arrive at a suitable ignition curve for your engine is to use the Ignition Timing Factors Chart as a guide and compare it to the Advance Graphs in Figure 2 until a suitable curve is found. When selecting your advance curve, use detonation (engine ping) as an indicator of too much advance, and a decrease in power as an indicator of too little advance.

### TIPS ON SELECTING AN ADVANCE CURVE

- Use as much initial advance as possible without encountering excessive starter load or engine kick-back.
- Start the centrifugal advance just above the idle rpm.
- The starting point of the centrifugal advance curve is controlled by the installed length and tension of the spring.
- How quickly the centrifugal advance (slope) comes in is controlled by the spring stiffness. The stiffer the spring, the slower the advance curve.
- The amount of advance is controlled by the advance bushing. The bigger the bushing, the smaller the amount of advance.

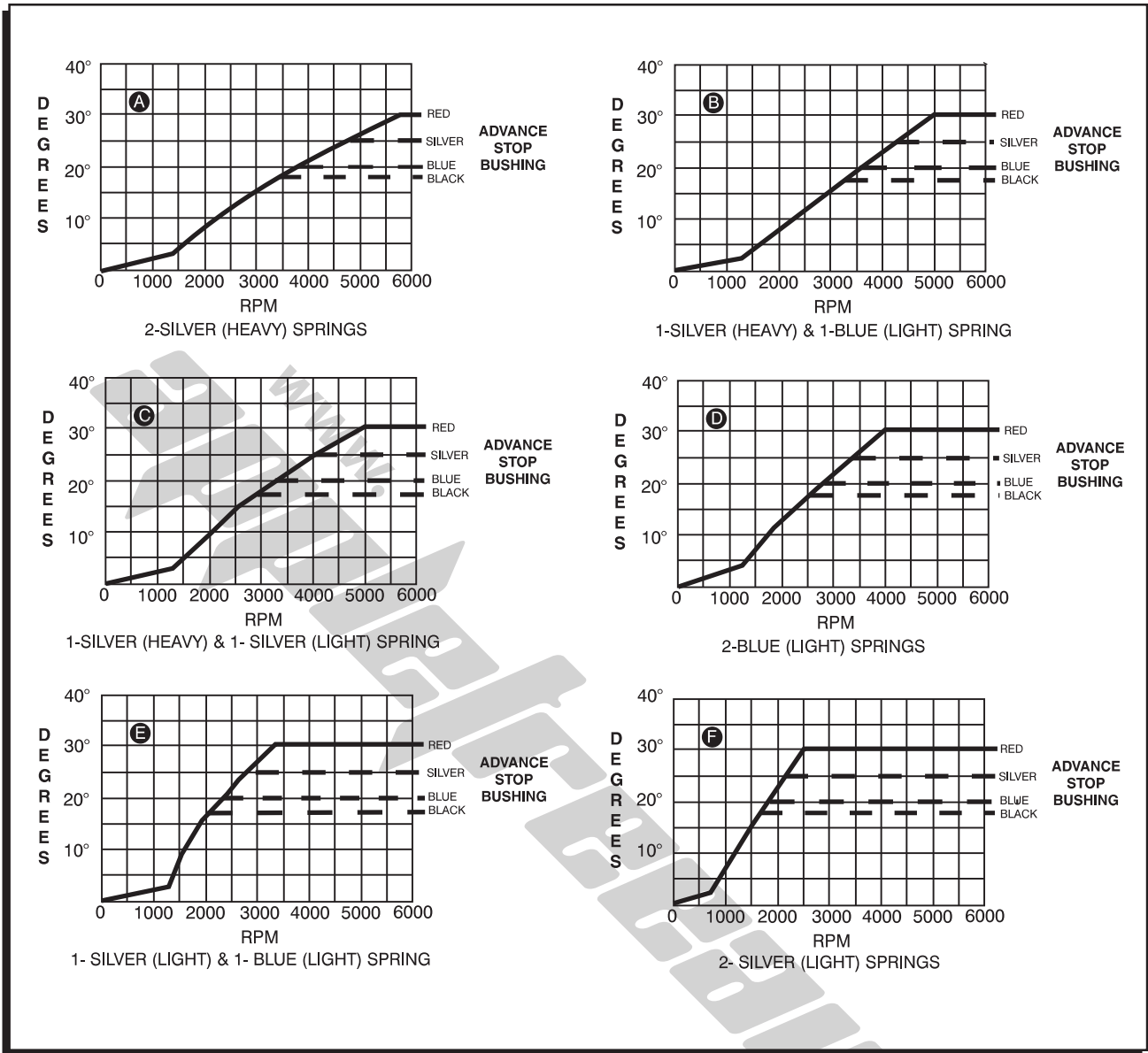

Figure 2 Advance Curves.

## CENTRIFUGAL ADVANCE CURVE

The centrifugal advance mechanism is made up of weights, springs, an advance cam and the advance stop bushing. The distributor can be used in a wide selection of applications by changing only the springs and the advance stop bushing. There is no need to change the weights or advance cam.

### SELECTING THE ADVANCE SPRINGS

The rate, or how quick the advance comes in is determined by the type of springs which are installed on the distributor. The MSD distributors are equipped with two Heavy Silver springs installed. These will give you the slowest advance curve possible. The parts kit contains two additional sets of springs which can be used to match the advance curve to your particular application. Refer to the Spring Combination Chart (Figure 3) for combinations that can be achieved.

SPRING COMBINATION	RATE OF ADVANCE	GRAPH NO. (Page 3)	
2- Heavy Silver	Slowest	A	
1- Heavy Silver 1- Light Blue		B	
1-Heavy Silver 1-Light Silver		C	
2- Light Blue		D	
1- Light Silver 1- Light Blue		E	
2- Light Silver		FASTEST	F

Figure 3 Spring Combination Chart.

### INSTALLING THE ADVANCE SPRINGS

1. Remove the distributor cap and rotor.
2. Using long needle nose pliers, remove the springs from the spring posts.
3. Install the new springs using the pliers and install the rotor and cap.

### SELECTING THE ADVANCE STOP BUSHING

Three different advance stop bushings are supplied in the distributor kit. The distributor comes with a Blue (10.5) bushing already installed. If a different amount of centrifugal advance is desired, follow the next procedure to change the bushings. The chart in Figure 4 gives the size and approximate degrees for the corresponding bushings.

BUSHING SIZE	APPROXIMATE CRANKSHAFT DEGREES
Red-Smallest	28
Silver	25
Blue	21
Black-Largest	18

Figure 4 Advance Stop Bushing Chart.

### CHANGING THE ADVANCE STOP BUSHINGS

1. Remove the distributor cap and rotor.
2. Remove the locknut and washer on the bottom of the advance assembly (Figure 5).
3. Remove the bushing and install the new one. Install the washer and locknut.

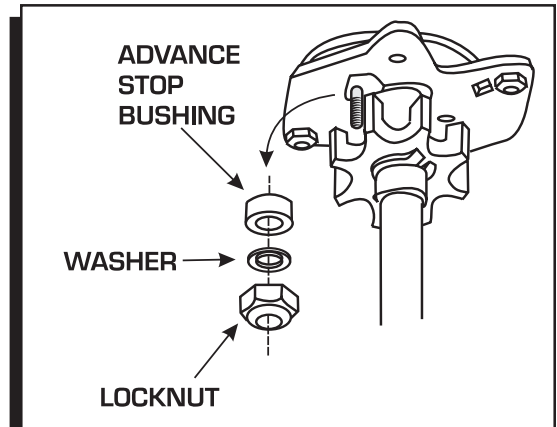

Figure 5 Changing the Advance Stop Bushing.

### LOCKING OUT THE CENTRIFUGAL ADVANCE

1. Remove the roll-pin from the drive gear and remove the gear from the shaft.
2. Remove the advance springs, weights and the advance stop bushing from the advance assembly.
3. Slide the shaft two inches out of the housing.
4. Rotate the shaft 180° and insert the advance stop bushing pin into the small hole on the advance plate (Figure 6).
5. Install the locknut and washer to the advance stop bushing pin.
6. Install the drive gear and roll-pin.

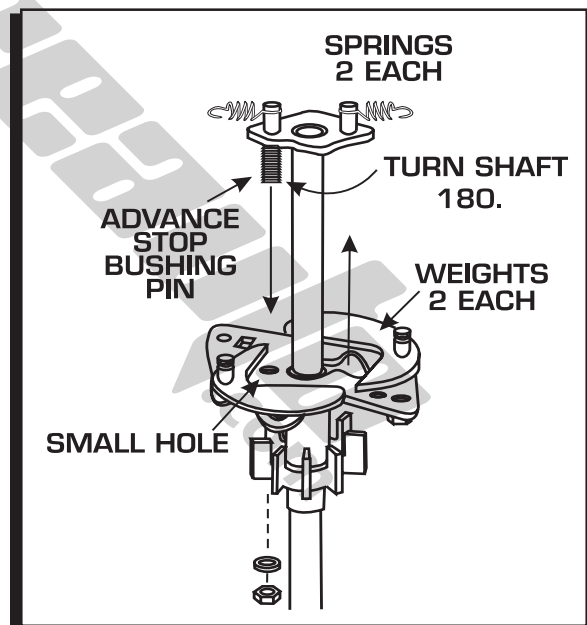
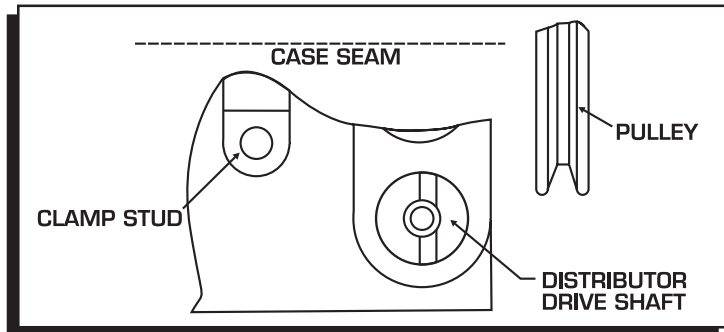

Figure 6 Locking Out the Centrifugal Advance.

## INSTALLING THE DISTRIBUTOR

1. Set the No. 1 cylinder to TDC under compression.
2. Remove the distributor cap. Note the position of the rotor and which spark plug terminal it is pointing to. Mark the plug wire and the position of the rotor.
3. Remove the distributor and the distributor shaft spring.
3. Make sure the position of the distributor driveshaft slot is perpendicular to the case seam (Figure 7). If not, move it to the proper position.



**Figure 7 Distributor Driveshaft Position.**

4. Remove the original clamp stud and install the supplied longer stud at least 1/2" into the case. Place the supplied spacer over the stud.
5. Install the collar and clamp to the distributor and snug the bolts (Figure 8). Install the distributor into the engine making sure that it bottoms out on the driveshaft.
6. Screw the nut onto the clamp stud and finger tighten. Locate the supplied shims and set one 0.010" shim aside.
7. With the remaining shims, make a stack that fits the gap between the clamp and the distributor housing (Figure 8). It is recommended to use a shim stack that is slightly thicker than the gap up to 0.005" however, it may be 0.002" thinner.
8. Remove the distributor then remove the clamp and collar. Add the one 0.010" shim that you set aside to the shim stack and place them on the distributor.
9. Install the clamp and collar so the shims are sandwiched between the housing and the clamp. Tighten the clamp and install the two o-ring seals or use the original seal if it's in good shape.
10. Install the distributor shaft spring and the distributor. Make sure the rotor is pointing to the number one terminal of the distributor cap.
11. Install the cap and spark plug wires. If you are using the original spark plug wires, the terminals and boots must be replaced with MSD 90° boots and terminals, PN 8850. MSD offers a set of custom length Heli-Core Wires for VW, PN 3193.

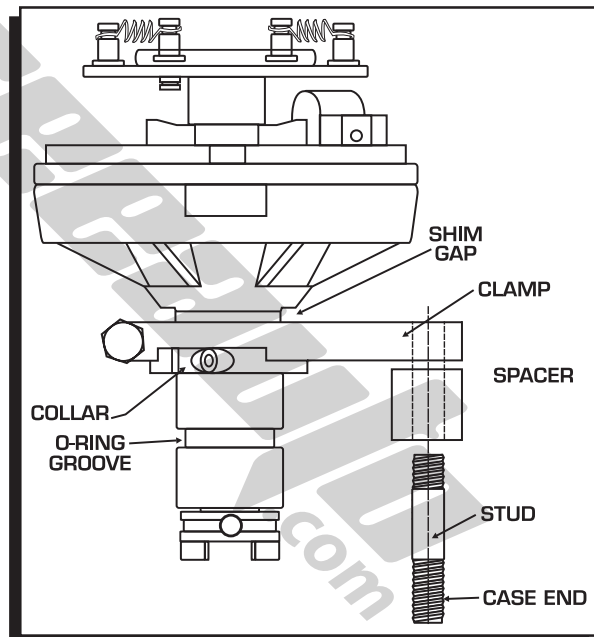

**Figure 8 Measuring the Required Distributor Shims.**

**WIRING**

The MSD Billet VW Distributor must be used with and MSD Ignition Control. Figure 9 shows the correct wiring of the ignition system.

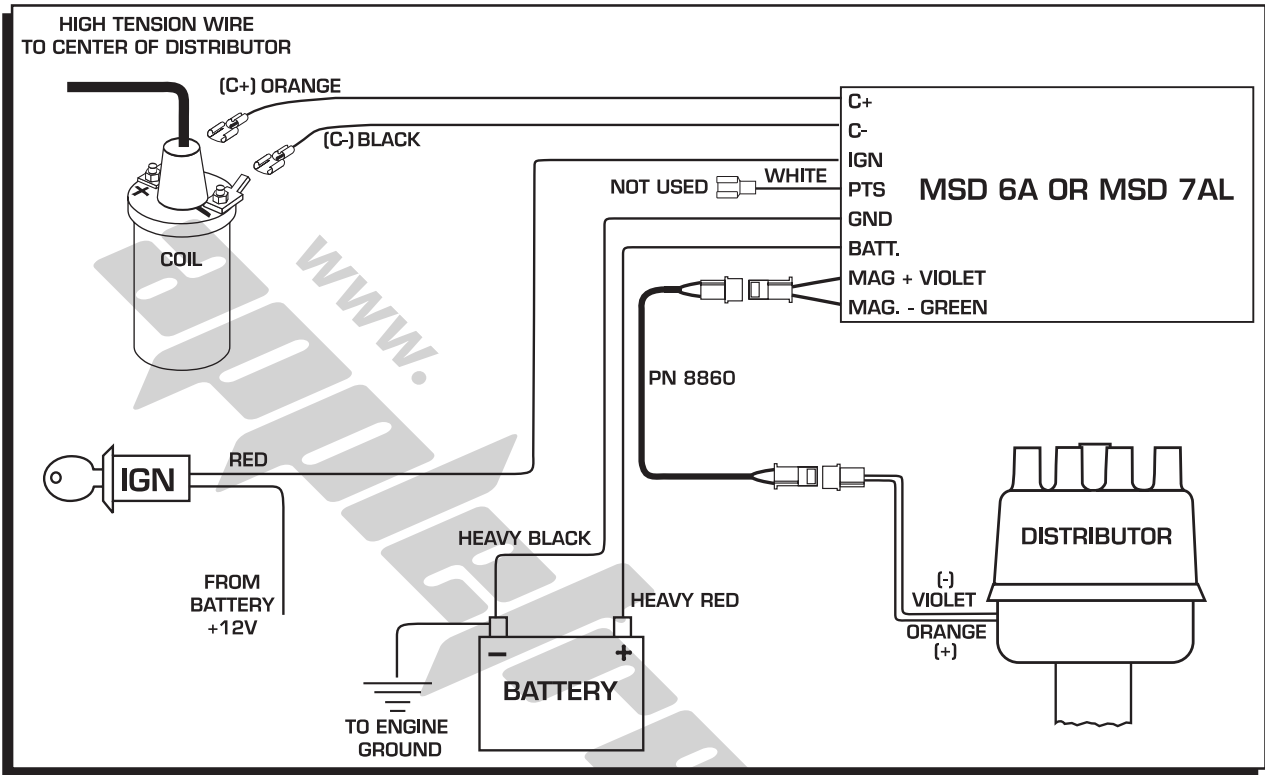

Figure 9 Wiring the Billet Distributor.

**TECH NOTES**

---

---

---

---

---

---

---

---

---

---

---

---



# INSTALLATION INSTRUCTIONS

## TECH NOTES

---

---

---

---

---

---

---

---

---

---

---

---

---

---

---

---

---

---

### Service

In case of malfunction, this MSD component will be repaired free of charge according to the terms of the warranty. When returning MSD components for service, Proof of Purchase must be supplied for warranty verification. After the warranty period has expired, repair service is charged based on a minimum and maximum charge.

Send the unit prepaid with proof of purchase to the attention of: **Customer Service Department, Autotronic Controls Corporation, 1490 Henry Brennan Drive, El Paso, Texas 79936.**

When returning the unit for repair, leave all wires at the length in which you have them installed. Cutting wires close to the unit will void your warranty. Be sure to include a detailed account of any problems experienced, and what components and accessories are installed on the vehicle.

The repaired unit will be returned as soon as possible after receipt, COD for any charges. For more information, call the MSD Customer Service Line (915) 855-7123. MSD technicians are available from 8:00 a.m. to 5:00 p.m. Monday - Friday (mountain time).

### Limited Warranty

Autotronic Controls Corporation warrants MSD Ignition products to be free from defects in material and workmanship under normal use and if properly installed for a period of one year from date of purchase. If found to be defective as mentioned above, it will be replaced or repaired if returned prepaid along with proof of date of purchase. This shall constitute the sole remedy of the purchaser and the sole liability of Autotronic Controls Corporation. To the extent permitted by law, the foregoing is exclusive and in lieu of all other warranties or representations whether expressed or implied, including any implied warranty of merchantability or fitness. In no event shall Autotronic Controls Corporation be liable for special or consequential damages.