

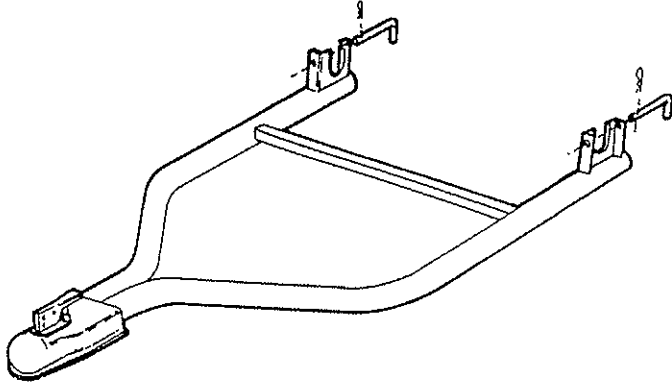

Tow Bar for Volkswagen Beetle Type I

(Not for Super Beetle with McPherson strut suspension)

- List of Parts:**
 Tow Bar (1)
 Pins (2)
 Spring Clips (2)
 Instruction Sheet (1)



Installation Instructions

1. The "U" shaped bracket on the end of each tow bar tube is designed to fit, with its open end up over the lower torsion tube (axle) of the front suspension.
2. The pins are now slid through one hole in the bracket (see diagram) and over the top of the torsion tube (axle) then through the other hole.
3. Snap the spring clips through the small holes in the end of the pins. It is vital to make sure that the clips are fully on the pins. They must be right up to the larger hole in the clip. (See diagram)

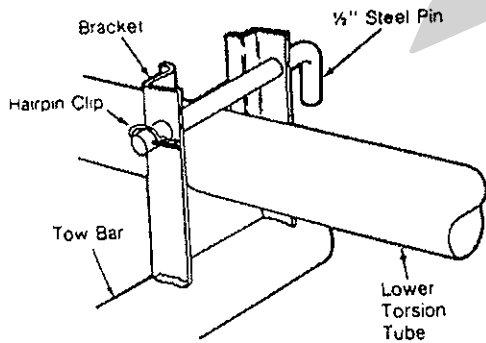

6. Install safety chains with identical or greater load rating as the tow bar. See diagram and suggestions below.
7. For additional security it is worth putting a small nut and bolt or padlock through the hole in the latch release lever. This will prevent the coupler accidentally being opened and also discourage tampering.

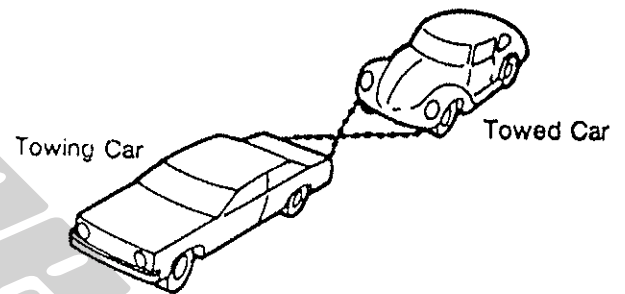

4. Adjust the coupler to correctly fit the ball as shown in the diagram below.

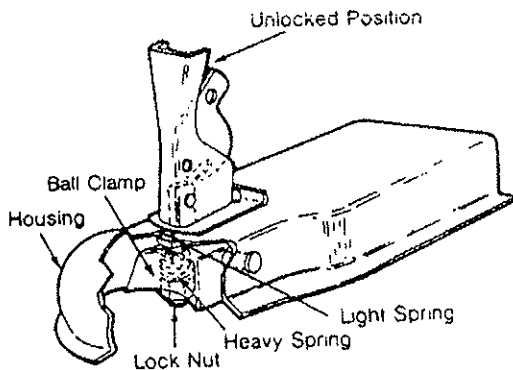

Adjusting the Coupler

- A. Place the coupler over the ball and lock it in position by pushing down on the locking lever.
- B. Adjust the coupler by rotating the lock nut until a good firm contact is made between the ball and the coupler.

5. If a pin or clip are lost always buy another identical set. Do not substitute with inferior material as this may fail in use and cause an accident.

Safety Chain Fitting

1. We suggest fitting the safety chains under the tow bar in the cross over pattern shown here.
2. Make sure the chain is firmly connected to the frame of both vehicles.

General Points

1. This tow bar is to be used on manual transmission models only. It cannot be used on Automatic Stick Shift Models.
2. Make sure the front wheel alignment on the car being towed is correct.
3. Disconnect the battery and with the ignition key unlock the steering column lock to allow the front wheels to follow the towing vehicle when cornering. The steering wheel must be allowed to rotate freely from lock to lock.
4. The tow bar must be parallel with the ground when it is attached to both vehicles. If it is angled there is the possibility of damage or an accident while towing. If it is found that an angle exists, the height of the tow bar on the towing vehicle will have to be changed.
5. Always use safety chains.
6. Make frequent checks of the installation when in use. Carefully examine all pins and the coupler adjusting bolt to make sure they are correctly fitted and in good condition. In addition check all welds for signs of cracks or distortion.
7. Do not use the towed car as a trailer for storing suitcases etc. as you may well exceed the towing capacity of the tow bar.
8. Do not back up when towing or damage to the towed vehicle's steering and suspension may result.